



Horizon Compact

15/27/kV Outdoor Circuit Breaker

A substation frame, stand or pole-mounted vacuum circuit breaker with SF₆ insulation in a self-contained package, the Horizon Compact expands our Horizon family of products. Featuring the most advanced operating mechanism available on the market today – the award winning magnetic actuator technology, the Horizon Compact offers unrivaled reliability, protection and environmental endurance for outdoor circuit breakers.

Designed for a 15kV or 27kV application, the Horizon Compact can be used with other products from Hawker Siddeley Switchgear to provide cost-effective and compact substations or breathe new life into existing substations by replacing old and obsolete equipment.

Key Features

- » Superior, proven 'Fit & Forget' technology with minimal maintenance
 - » Uses a magnetic actuator driven vacuum circuit breaker without the need for electronic control
 - » EPDM Bushings
 - » Corrosion resistant, light weight Aluminium tank and cover
 - » Dead tank construction suitable for live or dead tank applications
 - » Internal arc certified
 - » Cubicle with space for ancillary equipment and option for integrated control and customer specified protection relay
- » Substation frame, stand or pole-mounted, the Horizon Compact can be integrated into the most advanced distribution schemes or operate as a stand alone breaker
 - » Variety of mounting options provide compact solution where space is at premium

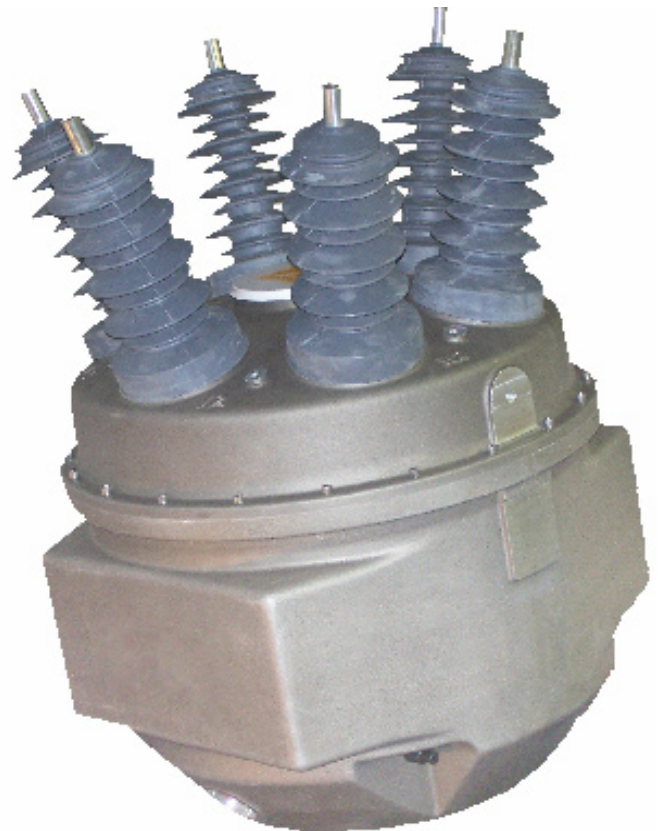

RATINGS

Maximum System Voltage	kV	15.5	27
Continuous Current	A	1250	1250
Interrupting Current	kA	25	25
Impulse Voltage Withstand	kV	110	125
Ambient Air Temperature	°C	-50 to +50	-50 to +50
Maximum Weight	lbs	650	650

ANSI Standards:

ANSI C37.06
ANSI C37.09

HAWKER SIDDELEY SWITCHGEAR

your power in safe hands

DIMENSIONS (In Inches)

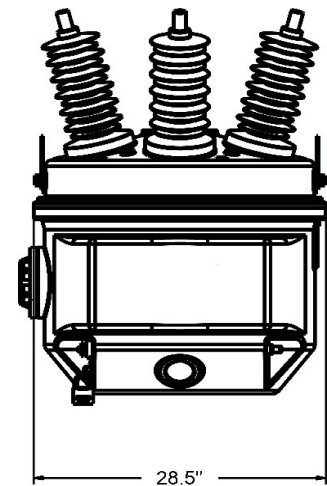
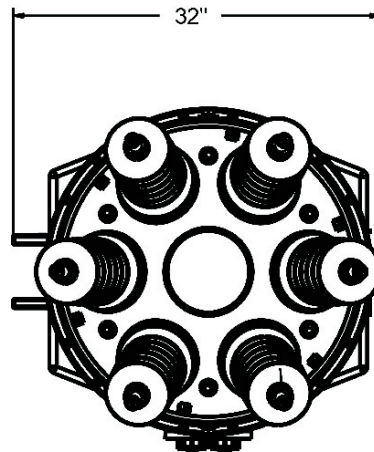
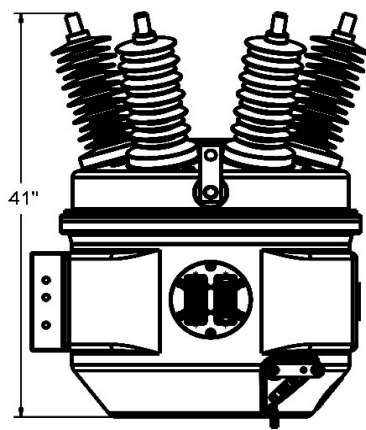

Horizon Compact Mechanical Features

- 1 EPDM bushings with a variety of terminal connection options available.
- 2 Current Transformers are located inside the aluminium housing, providing sealed protection from the environment.
- 3 Lightweight aluminium housing, secured by stainless steel bolts and incorporating rubber 'O' ring seals.
- 4 Pressure-relief disc, to comply with IEC 60298, offering the highest levels of safety.
- 5 Mechanical ON/OFF position indication visible through clear viewing window from ground level.
- 6 Manual trip and lockout handle on the side of the Horizon Compact tank.
- 7 A single moulding supports the three phase vacuum interrupter assembly, magnetic actuator mechanism and one-piece drive beam.
- 8 Bulkhead connection to control cubicle.

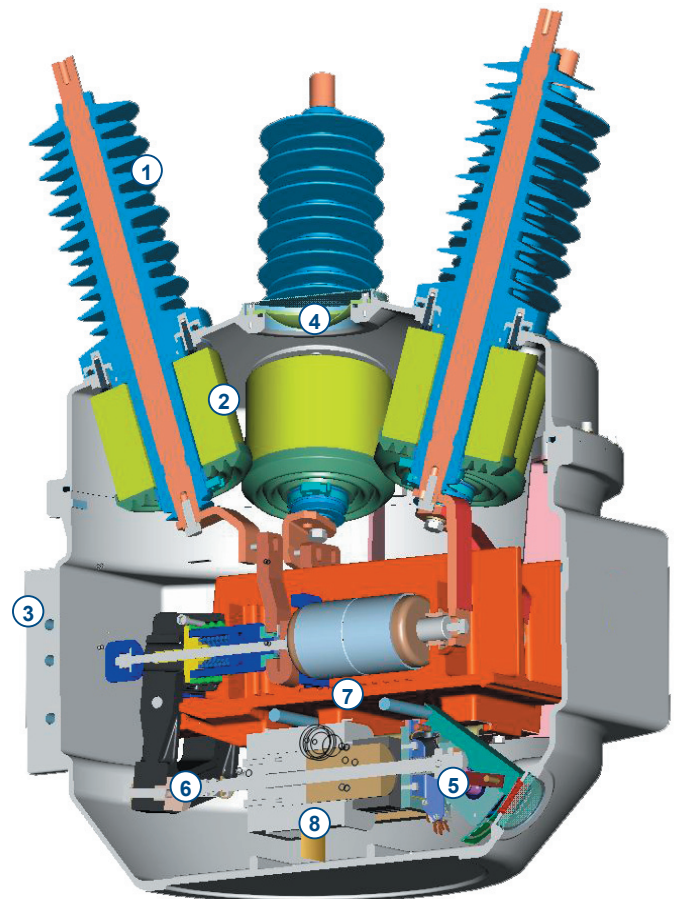

Hawker Siddeley Switchgear Ltd Tel: +44 (0)1495 223001 Email: sales@hss-ltd.com

Hawker Siddeley Switchgear Pty Australia Tel: +61 (0) 7 3888 2333 Email: hssaus@hss-ltd.com

Hawker Sideley Switchgear South America Tel: +57 (0)1 256 4617 Email: sales@hss-ltd.com

Hawker Siddeley Switchgear Ltd Technology Centre Tel: +44 (0)1706 674000 Email: sales@hss-ltd.com

Whipp & Bourne Inc. Tel: +1 (0) 757 858 8972 Email: whippinc@hssl-usa.com

www.hss-ltd.com